

Examples of MFI-New-Part2 from MFI Part3 Ed2

OKABE, Masao

Editor

MFI New Part2

2010.5.20

MFI-new-Part2 Core model as of 2010/5/19

<MDR>

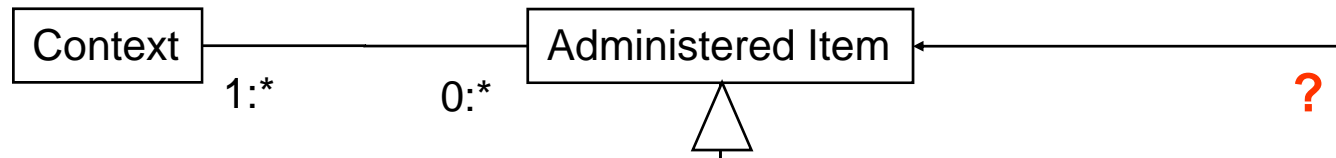

<MFI>

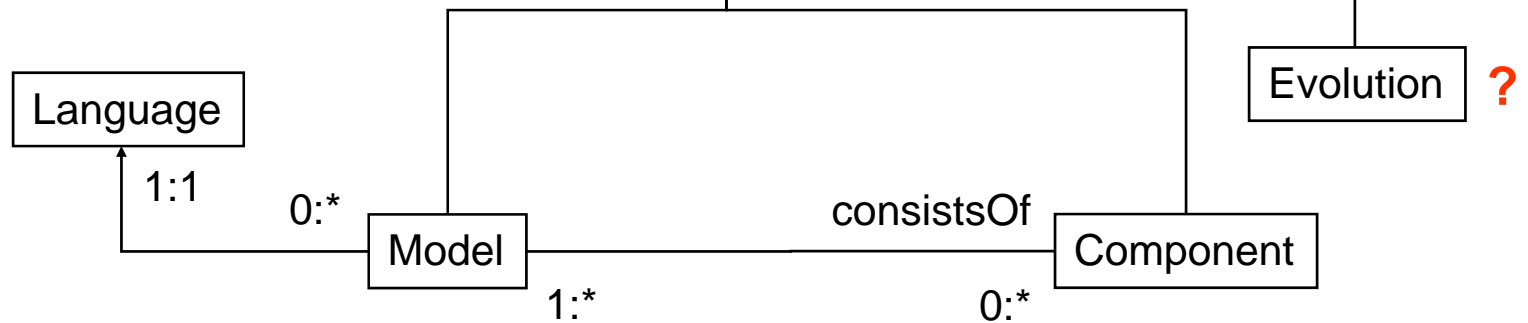

Instance example



needs a constraint which says context C and D shall be consistent

MFI Part3 Ed2 Basic_Model

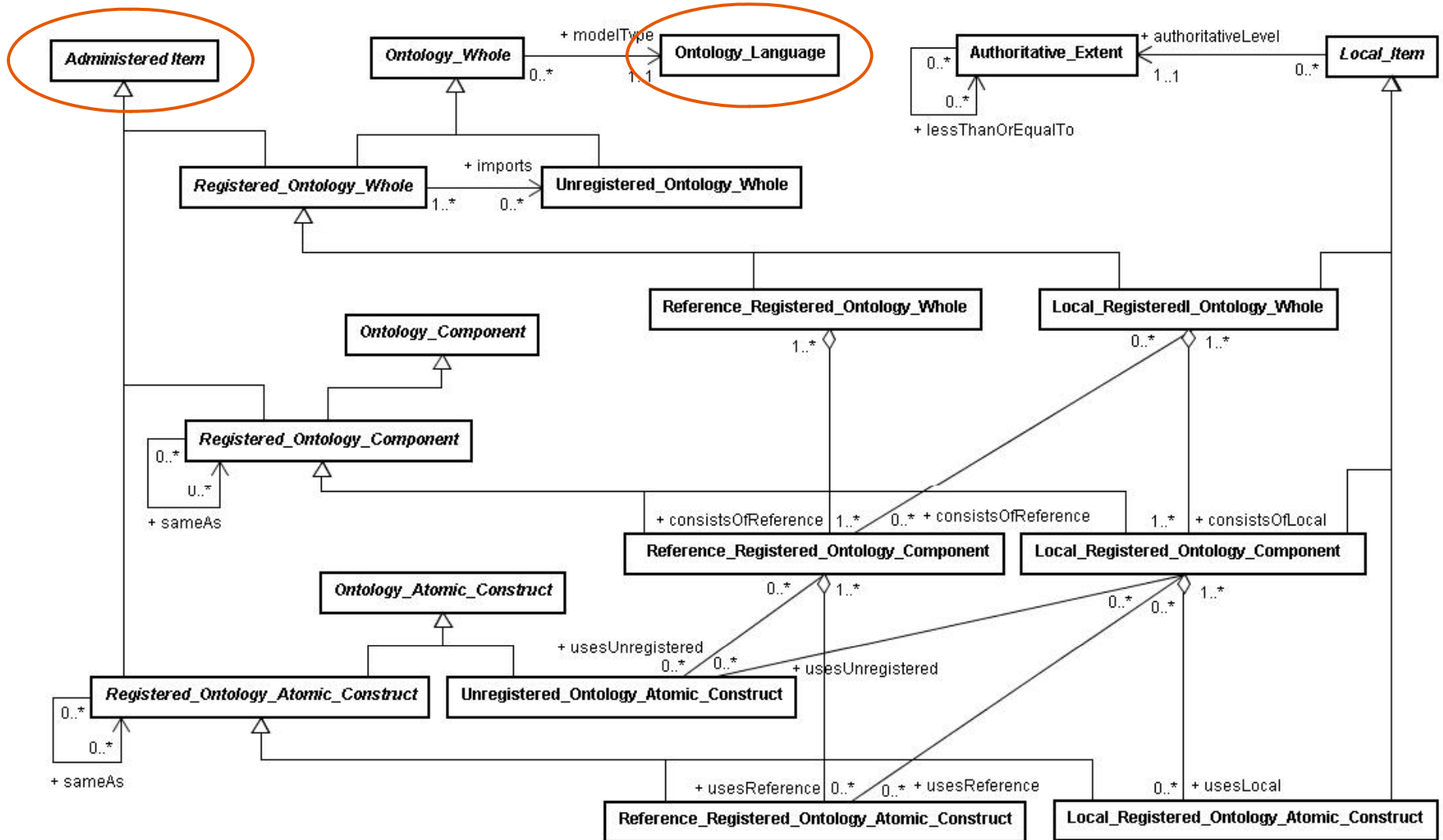

revised MFI Part3 Basic_Model

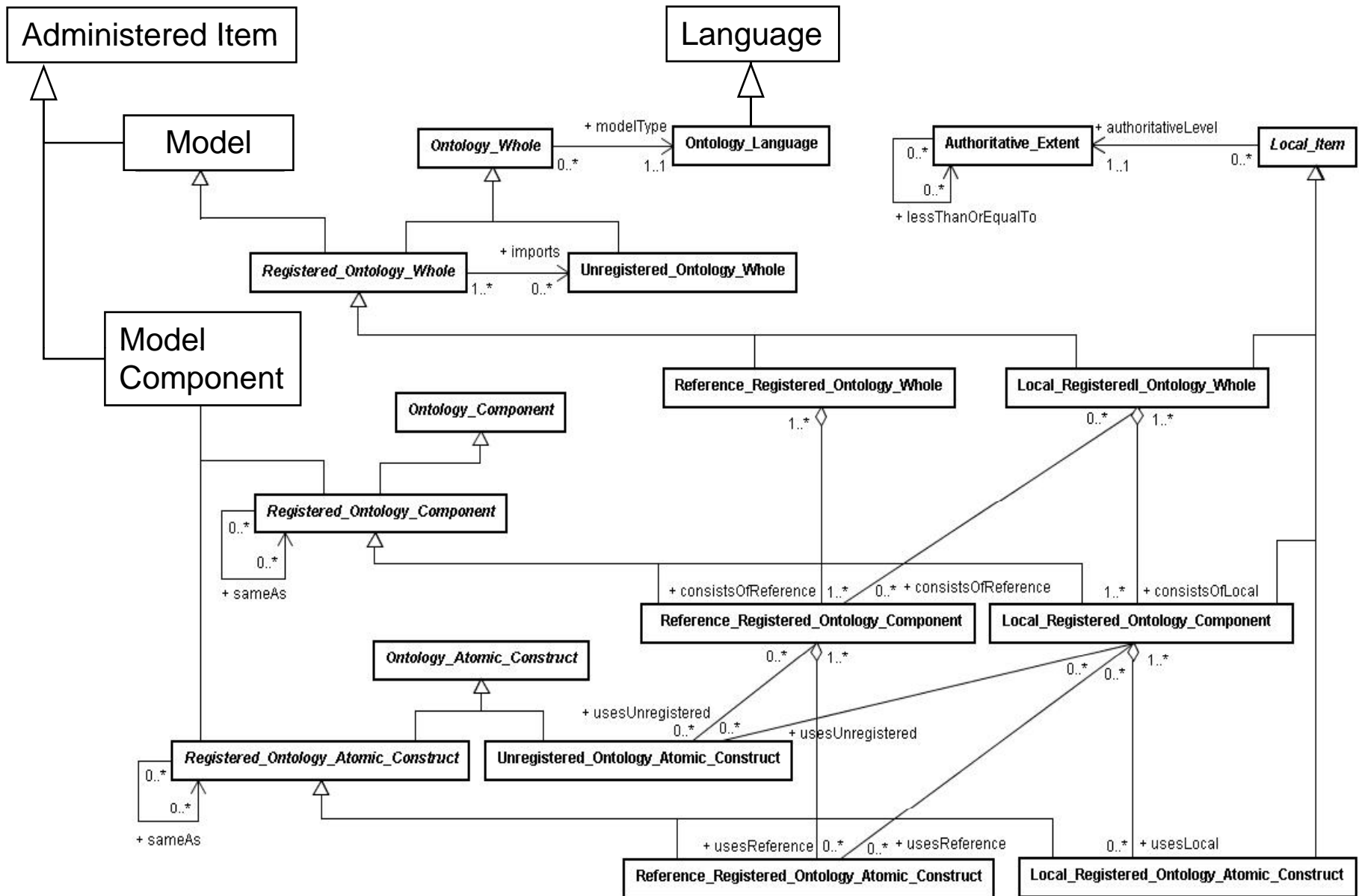

MFI Part3 Ed2 Evolution_Model

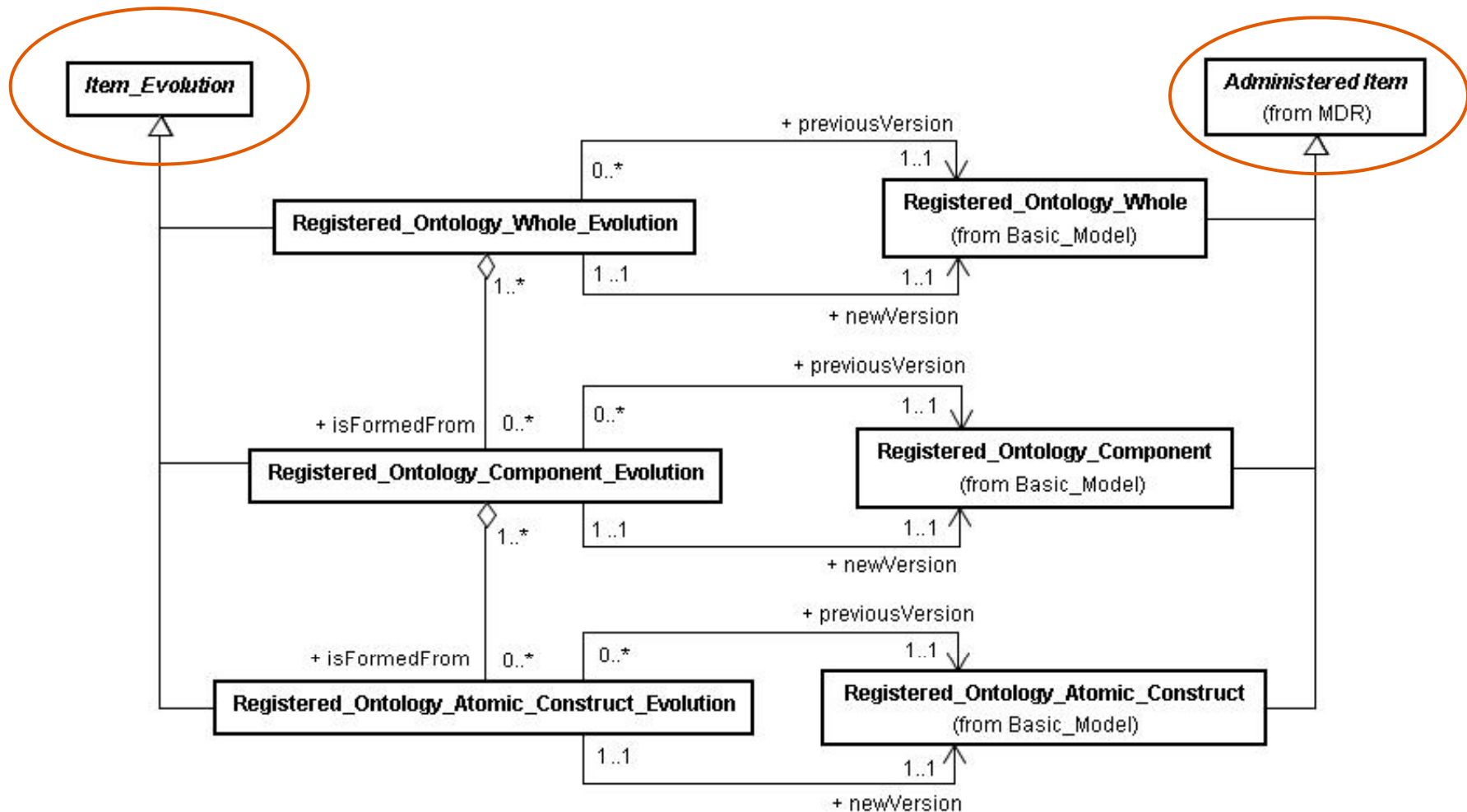

revised MFI Part3 Evolution_Model

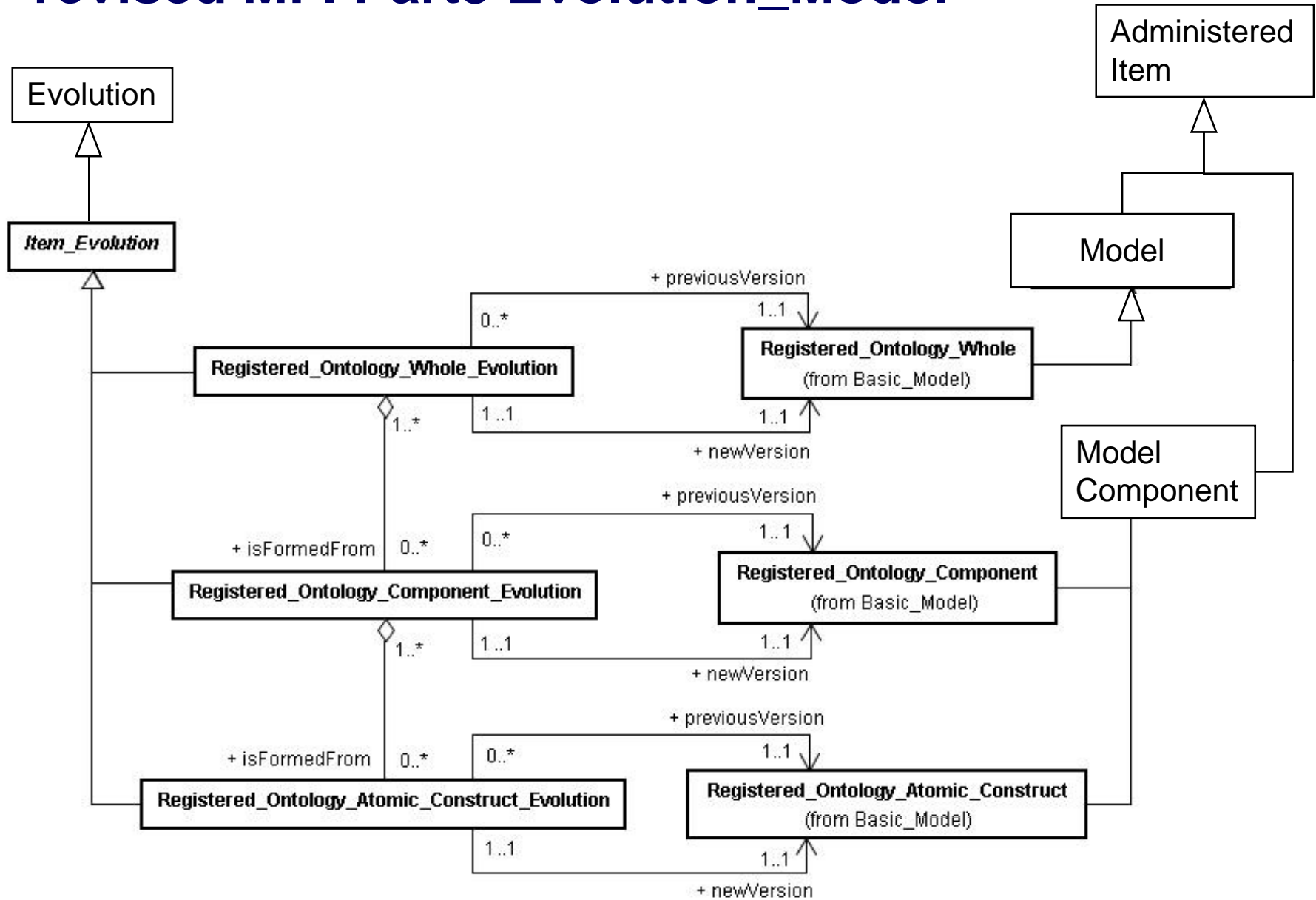

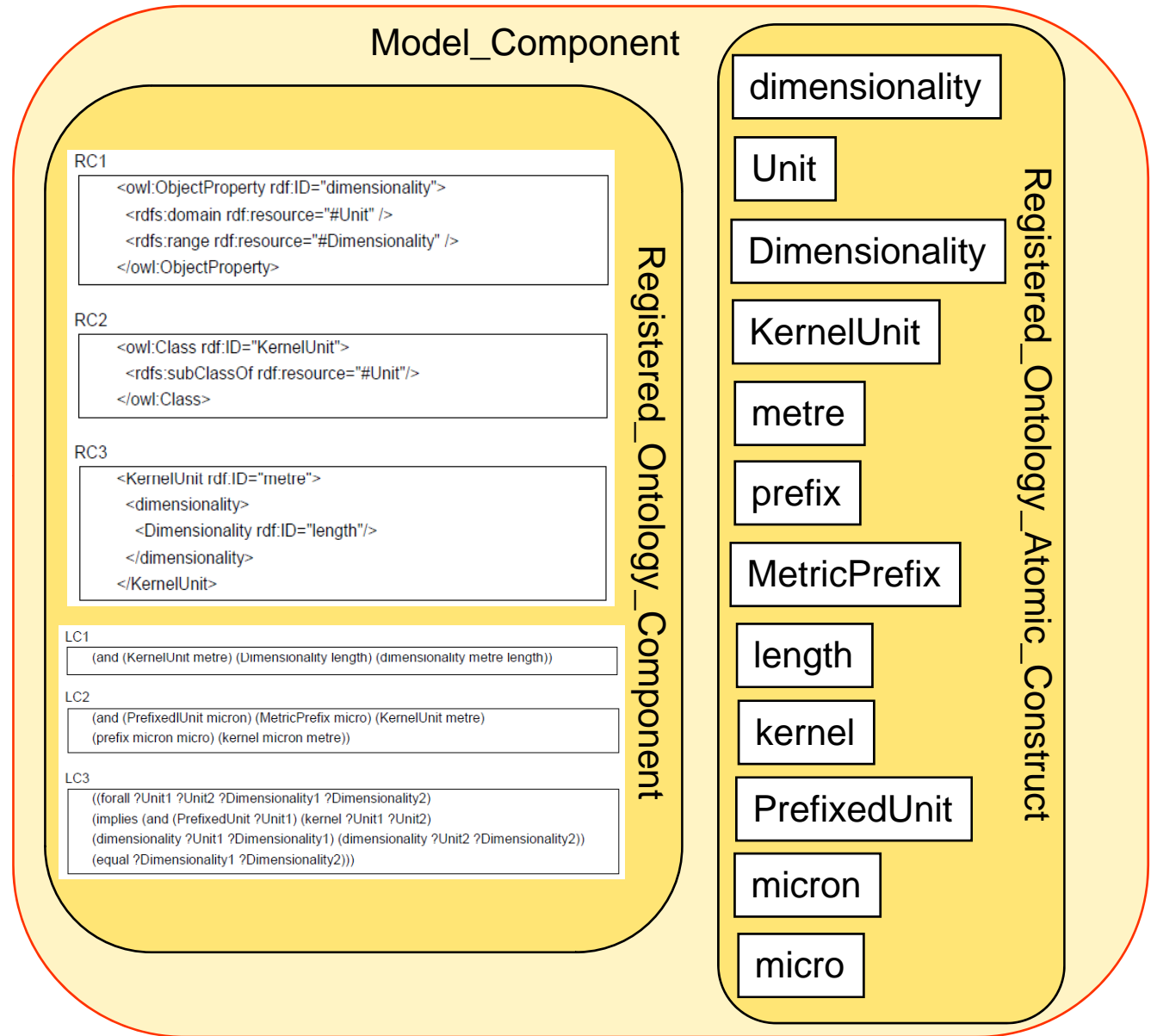
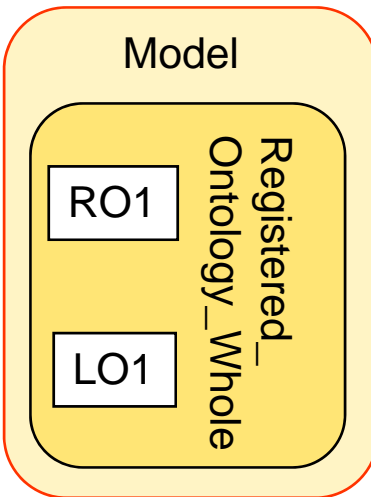
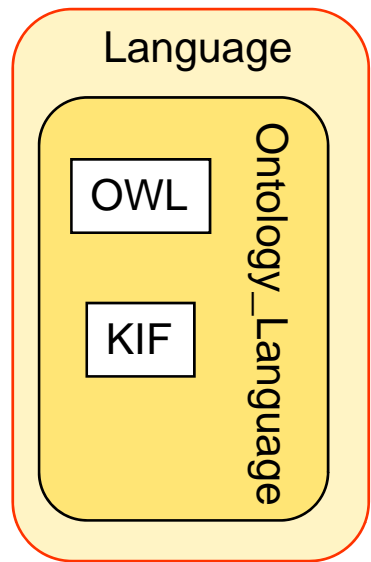

Legend:

MFI Core metaclass

MFI Part3 metaclass

Instance

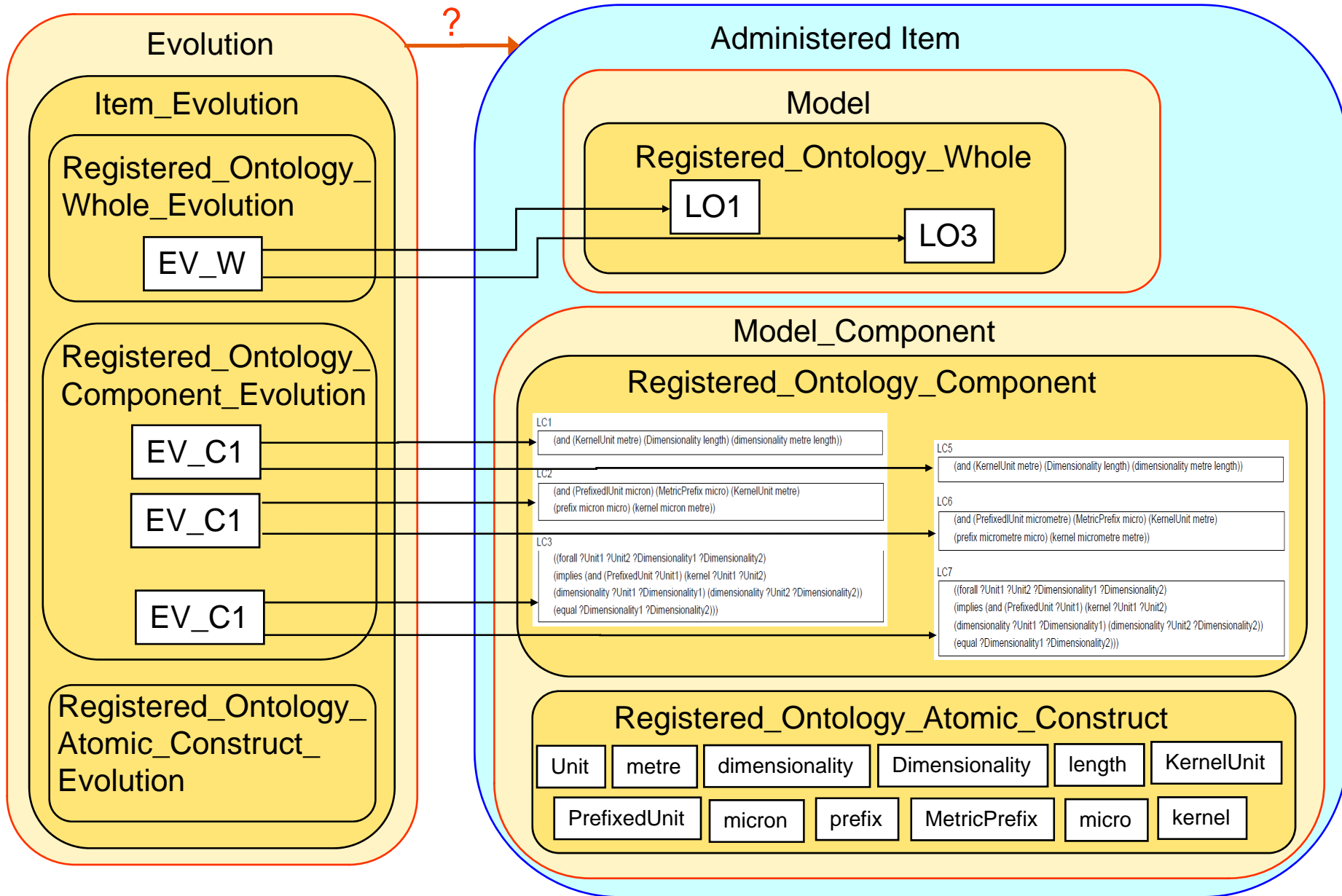

Legend: MDR MFI Core metaclass MFI Part3 metaclass Instance