



# MFI-3 Ontology Evolution Management Metamodel

HE Keqing

HE Yangfan

2006/8

# Talk Outline

---

1. Background
2. Overall design of MFI-3
3. Ontology Evolution Management Metamodel
4. Future Work

# Talk Outline

---

1. Background
2. Overall design of MFI-3
3. Ontology Evolution Management Metamodel
4. Future Work

# What is ontology evolution

---

- ✍ Ontology Evolution is the timely adaptation of an ontology to the arisen changes and the consistent propagation of these changes to dependent artefacts.

From *Ontology versioning for the Semantic Web*, Michel Klein, Dieter Fensel, Vrije Universiteit Amsterdam

- ✍ Ontology Evolution is the process to manage ontology changes and their effects by creating and maintaining different variants of the ontology.

From *Ontology Evolution: Not the Same as Schema Evolution*, Natalya F. Noy and Michel Klein, Stanford University, Vrije Universiteit Amsterdam

- ✍ Consistent Ontology Evolution is the process of managing ontology changes by preserving the consistency of the ontology with respect to a given notion of consistency.

From *A Framework for Handling Inconsistency in Changing Ontologies*, P. Haase, F. van Harmelen, Z. Huang, H. Stuckenschmidt, and Y. Sure, University of Karlsruhe, Germany

# Key Problems

---

## ✍ Change Management

- ✍ How to describe the change?
- ✍ How to describe the effect of the change?

## ✍ Change Propagation

- ✍ How to keep the consistency between the changing ontology and dependent ontologies.

# Model change Management

---

- ✍ Software Maintaining

  - ✍ Versioning

  - ✍ Change Log

- ✍ General Principles

  - ✍ Backward Compatibility

- ✍ ISO/IEC 11179-6

  - ✍ Metadata Lifecycle Management

# Ontology Change

---

- ✎ Reasons for ontology change
  - ✎ Correct some errors in the ontologies
  - ✎ Adapt the ontology according to users' feedback
  - ✎ ...
- ✎ Basic classification of ontology changes
  - ✎ **conceptual change**: a change in the conceptualization;
    - ✎ Change in UoD
  - ✎ **specification change**: a change in the specification of a conceptualization;
    - ✎ View change
  - ✎ **representation change**: a change in the representation of a specification of a conceptualization.
    - ✎ Language change

# Talk Outline

---

1. Background
2. Overall design of MFI-3
3. Ontology Evolution Management Metamodel
4. Future Work

# MFI-3

---

- ✍ Currently, MFI-3 is an ontology registration facility
  - ✍ In 2nd Edition, MFI-3 will provide support for
    - ✍ Ontology registration
    - ✍ Registration for ontology evolution related artifacts
- ✍ Foundation for Semantic Interoperation promised by MFI

# Crucial Technical Problems

---

- ✍ How to registrate ontologies?
- ✍ What kind of changes can be identified and described by MFI-3?
- ✍ How to realign the dependent ontologies during the evolution process?
- ✍ How to keep the evolution information about ontologies

# Our Solution (1/2)

---

- ✍ How to registrate ontologies? **Kernel Model**
- ✍ What kind of change can be identified and described by MFI-3? **Change Model**
- ✍ How to realign the dependent ontologies during the evolution process? **Constraint Model**  
**Change Propagation Model**
- ✍ How to keep the evolution information about ontologies **Evolution Information Model**

# Our Solution (2/2)

---

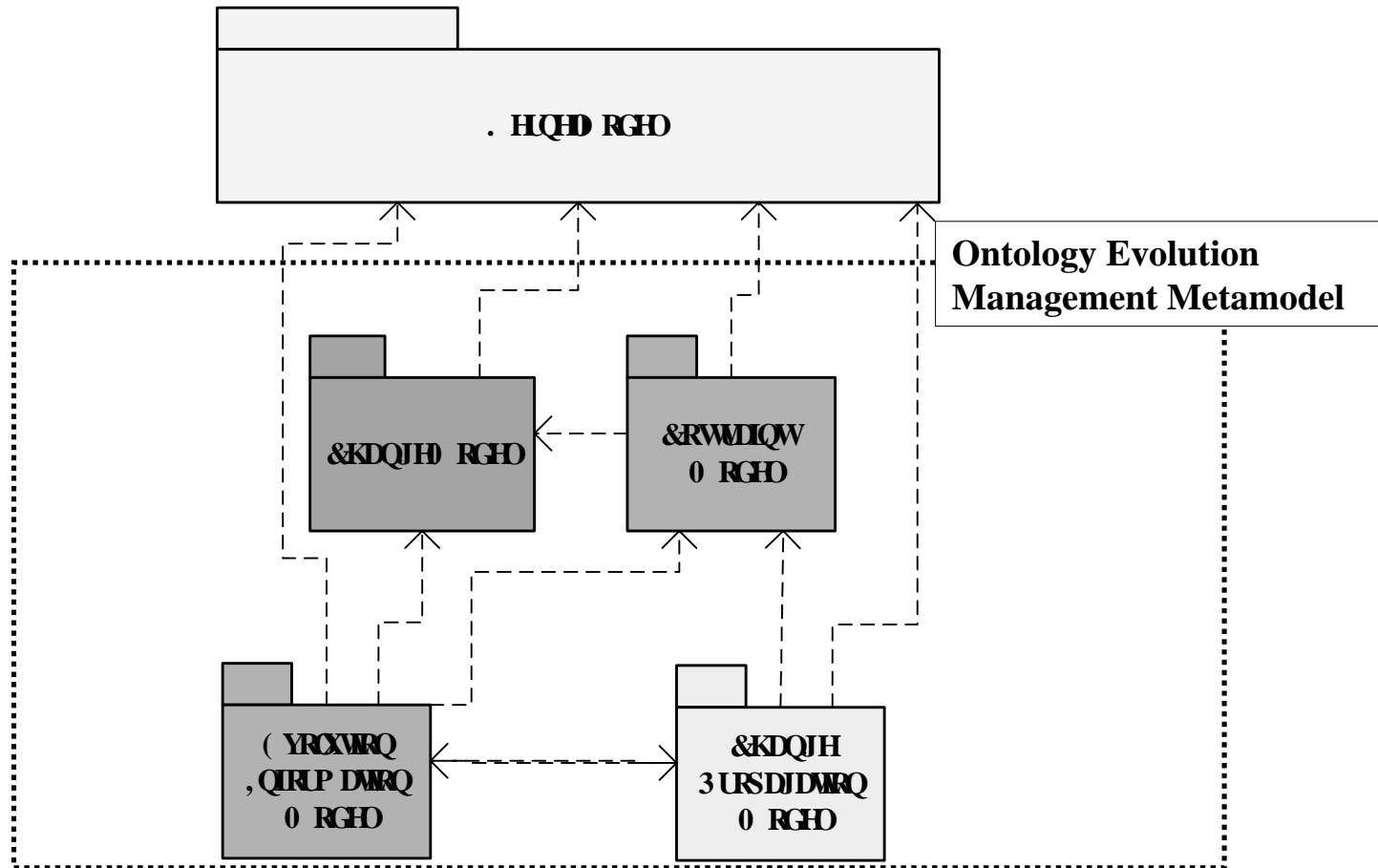

# MFI-3 Kernel Model

---

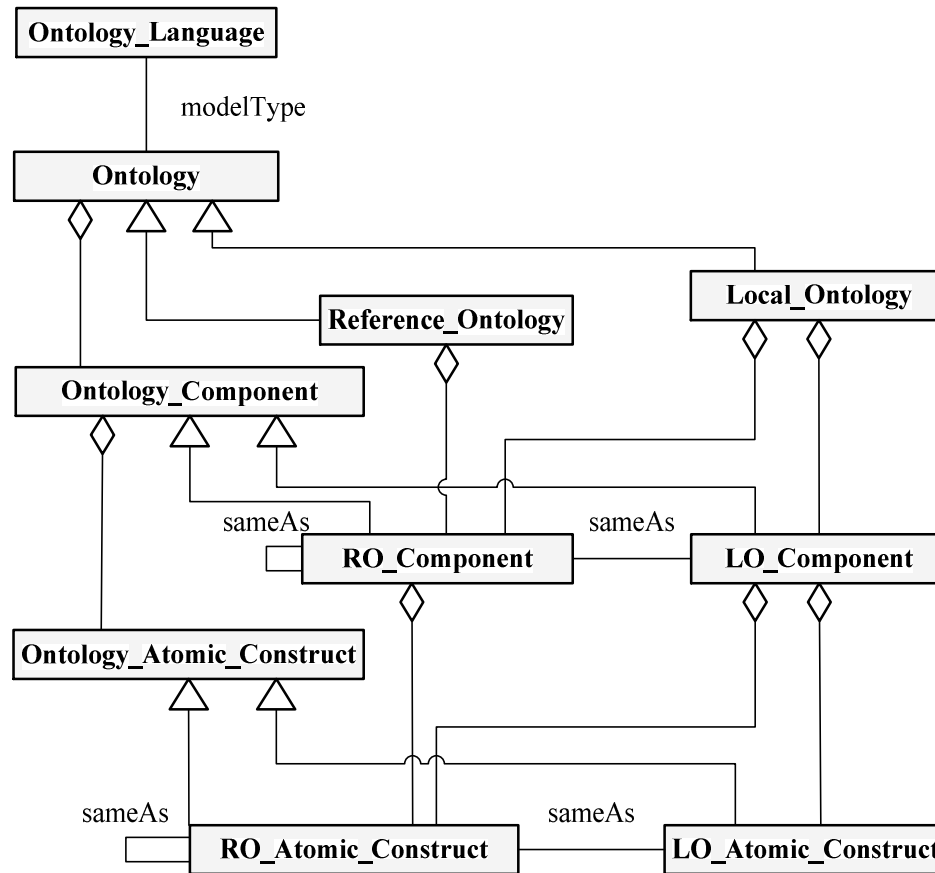

# Talk Outline

---

1. Background
2. Overall design of MFI-3
3. Ontology Evolution Management Metamodel
  1. An Example
  2. Key Concepts
  3. Onto Evo Mgt Metamodel
4. Future Work

# Reference Ontology X

---

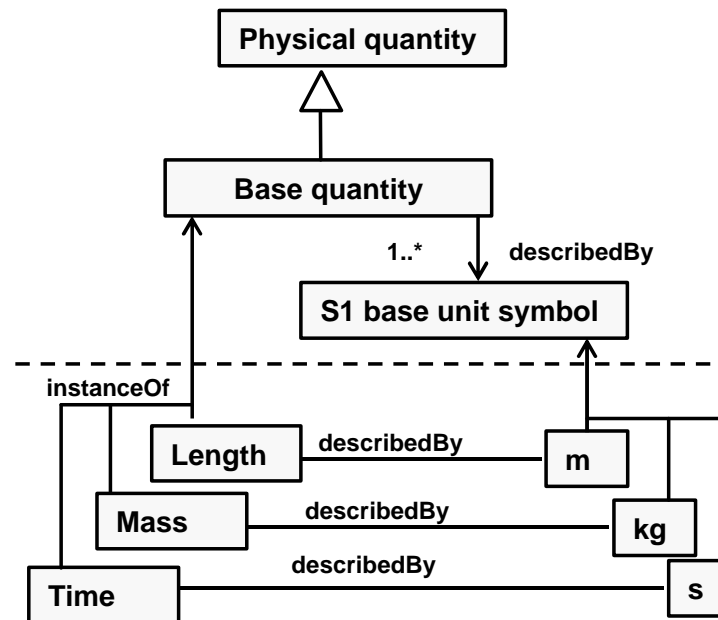

*From Annex A of MFI for Ontology Registration 1st CD*

# Reference Ontology Y

---

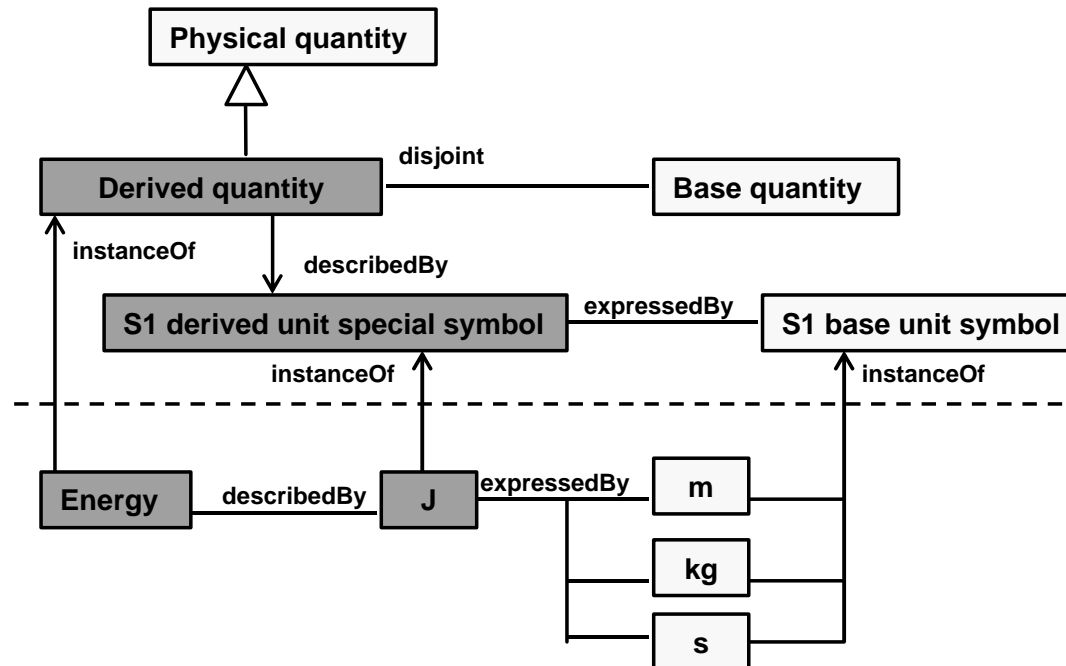

*From Annex A of MFI for Ontology Registration 1st CD*

# Local Ontology Z based on X and Y

---

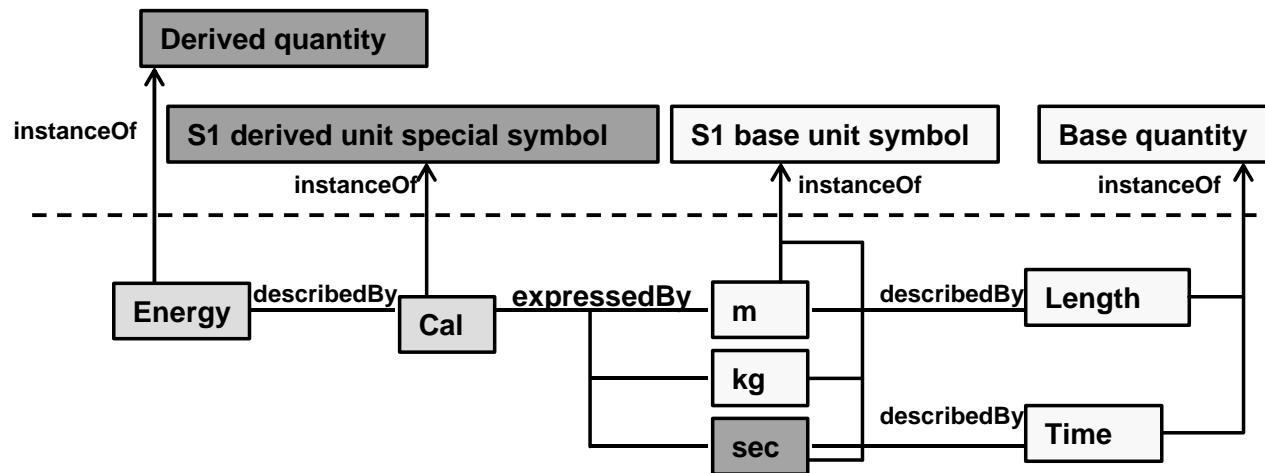

*From Annex A of MFI for Ontology Registration 1st CD*

# Local Ontology W based on X and Y

---

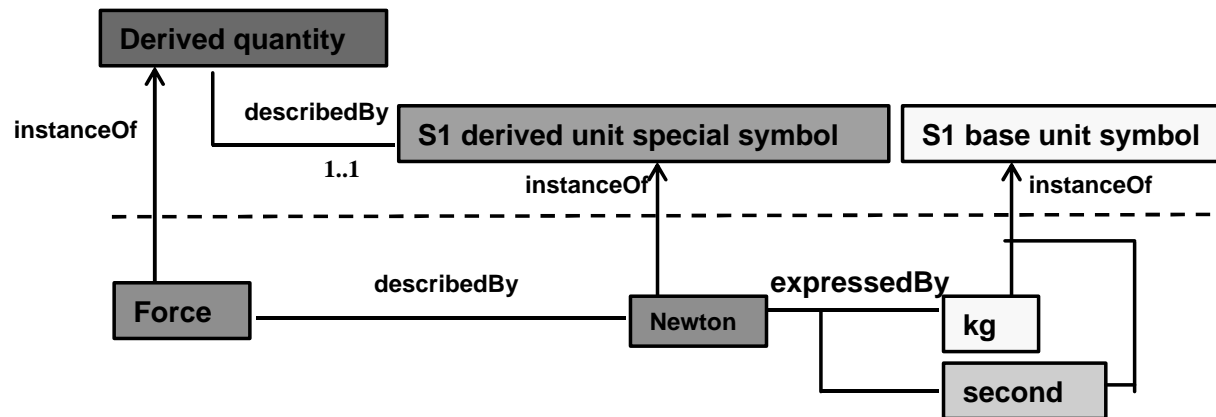

# Ontology Evolution Management

---

## ✍ Suppose

- ✍ Domain Experts requested some change applied on X.

## ✍ Let's see

- ✍ How to describe the change
- ✍ The effect of the change
- ✍ How to realize the changes?
- ✍ How to propagate the changes to Y,Z and W
  - ✍  $X \rightarrow X', Y \rightarrow Y', Z \rightarrow Z', W \rightarrow W'$

# X-->X' (1/11)

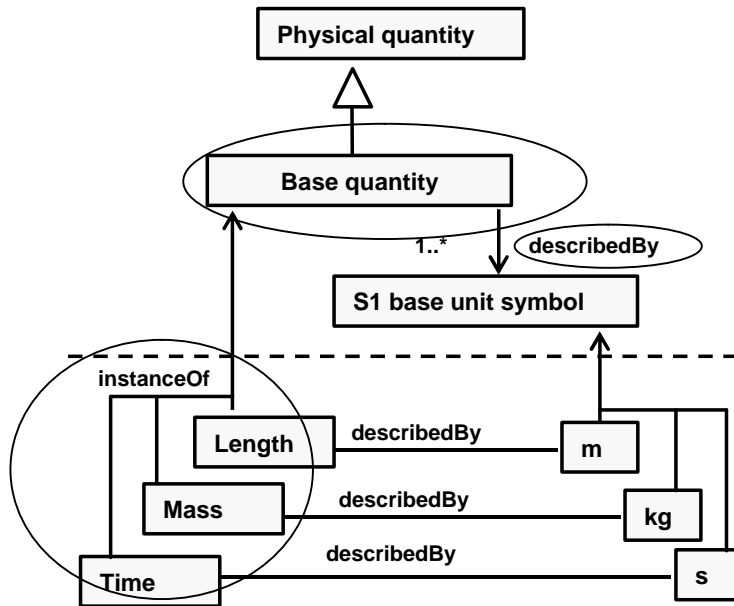

- delete class( Base quantity)
  - Atomic Change
  - User requested change
- Change Closure for “delete class (Base quantity)”
  - Delete class (Base quantity)
  - Delete instance of( Base quantity; Length, Mass, Time)
  - Delete property Domain( described By)
  - Delete individual(Length,Mass,Time)
  - ...
- Change closure :
  - Requested change  $\not\subseteq$  minimal set of changes
  - Maintain the integrity of ontology
- Constraint between changes

# $X \dashrightarrow X'$ (2/11)

## Constraint between changes

---

|                 | Additional changes   |
|-----------------|--|
| Delete concept  | <ol style="list-style-type: none"><li>1. Delete subconcept</li><li>2. Delete instanceOf</li><li>3. Delete individual</li><li>4. Delete property domain</li><li>5. Delete Property range</li><li>6. ...</li></ol> |
| Delete property | <ol style="list-style-type: none"><li>1. Delete property domain</li><li>2. Delete property range</li></ol>   |
| ...             |  |

$X \rightarrow X'$  (3/11)

## Atomic and Composite Change

### ✍ Atomic Change

- ✍ Applied on Atomic construct
- ✍ Indecomposable

### ✍ Composite Change

- ✍ Consists of Atomic Changes or Composite Changes
- ✍ Order

# X-->X' (4/11)

## Atomic changes based on MFI-3

---

|   | <b>Object (Atomic Construct Type)</b> | <b>Operation</b> | <b>Argument</b>                            |
|---|---------------------------------------|------------------|--|
| <b>Add class</b>                            | class                                 | Add              | URI of class                               |
| <b>Delete class disjoint</b>                | disjoint relationship                 | Delete           | URI of classes                             |
| <b>Add super-subclass relationship</b>      | Classes                               | Add              | URI of classes                             |
| <b>Delete property domain</b>               | property                              | Modify           | URI of Property,<br>URI of class           |
| <b>Delete cardinality upper lower bound</b> | Property                              | Modify           | URI of Property,<br>Domain/Range,<br>Value |
| <b>Add equivalence between Individuals</b>  | individual                            | add              | URI of individuals                         |
| <b>Add individual</b>                       | individual                            | add              | URI of individual                          |
| ...   |                                       |                  |  |

# X-->X' (5/11)

## Composite changes based on MFI-3

---

|                          | Consists of   | Constraint   |
|--------------------------|---|--|
| Modify_Range_To_Subclass | <ol style="list-style-type: none"><li>1.Add Range (Property, Class)</li><li>2.Delete Range (Property,Class)</li></ol>                     | The class in Step1 argument list is the subclass of the class in Step2 argument list |
| Add_Subtree              | <ol style="list-style-type: none"><li>1.Add class() for several times</li></ol>   | The classes added form a tree with the root linked to a class in original ontology   |
| Delete_Siblings          | <ol style="list-style-type: none"><li>1. Delete class for several times</li><li>2. Add the subclasses to original super classes</li></ol> | The classes deleted are located in the same depth                                    |
| Merge_Siblings           | <ol style="list-style-type: none"><li>1.Add class</li><li>2. Delete siblings</li><li>3. Add super-subclass relationship</li></ol>         |  |
| ...                      |   |  |

# X-->X' (6/11)

## Change Closure

---

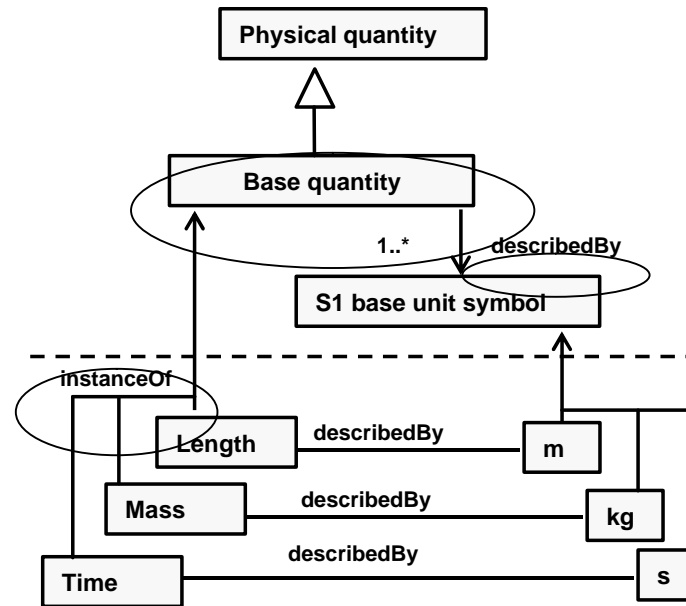

User requested change : delete class( Base quantity)

Change closure :

Delete class (Base quantity)

Delete instance of( Base quantity; Length, Mass, Time)

Delete property Domain( described By)

Delete individual(Length,Mass,Time)

...

# $X \dashrightarrow X'$ (7/11)

## User's requirement for ontology evolution

---

### ✎ Change

- ✎ Atomic & Composite Change
- ✎ Constraint Between Changes
- ✎ Change Closure

### ✎ What can not be changed

- ✎ Backward Compatibility principle
- ✎ Consistency constraint

# $X \dashrightarrow X'$ (8/11)

## Consistency Constraint

---

- ✍ A set of model elements , which can not vanish during the evolution.
  - ✍ Model elements
    - ✍ Ontology Atomic Construct
    - ✍ Ontology Component
  - ✍ Consistency Closure

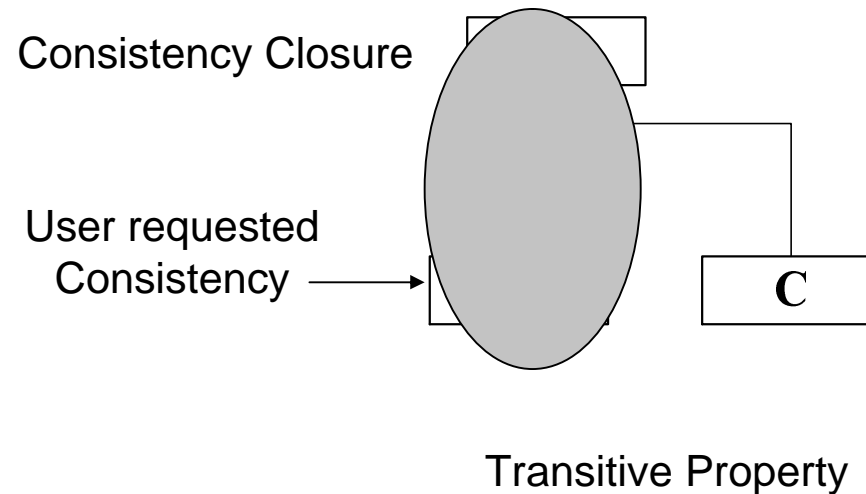

# X-->X' (9/11)

## Consistency Constraint

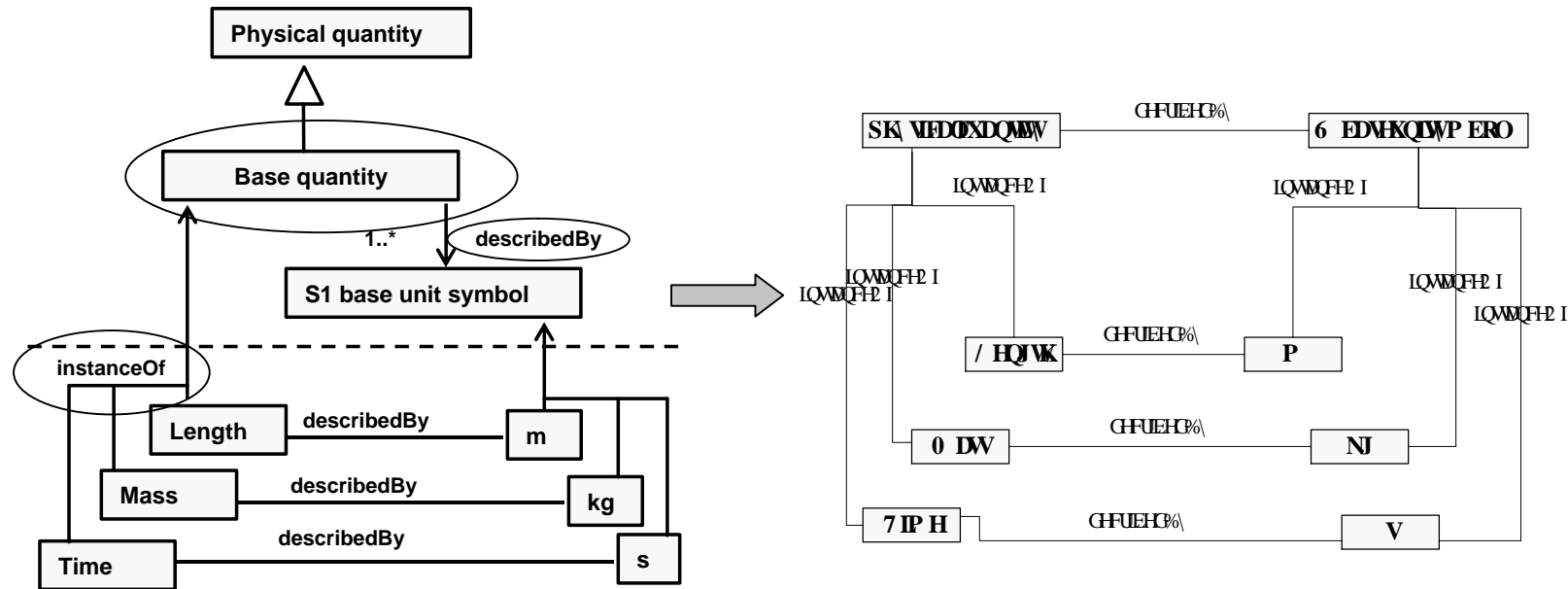

- User requested changes :{delete class (Base quantity)}
- User requested consistency : {Length, Mass,Time}
- Additional changes:
  - Add individual (Length, Mass,Time)
  - Add instance of( physical quantity; Length, Mass,Time)
  - Add Property Domain( described By, physical quantity)
  - ...

Evolution Strategy

# X-->X' (10/11)

## Evolution Strategies

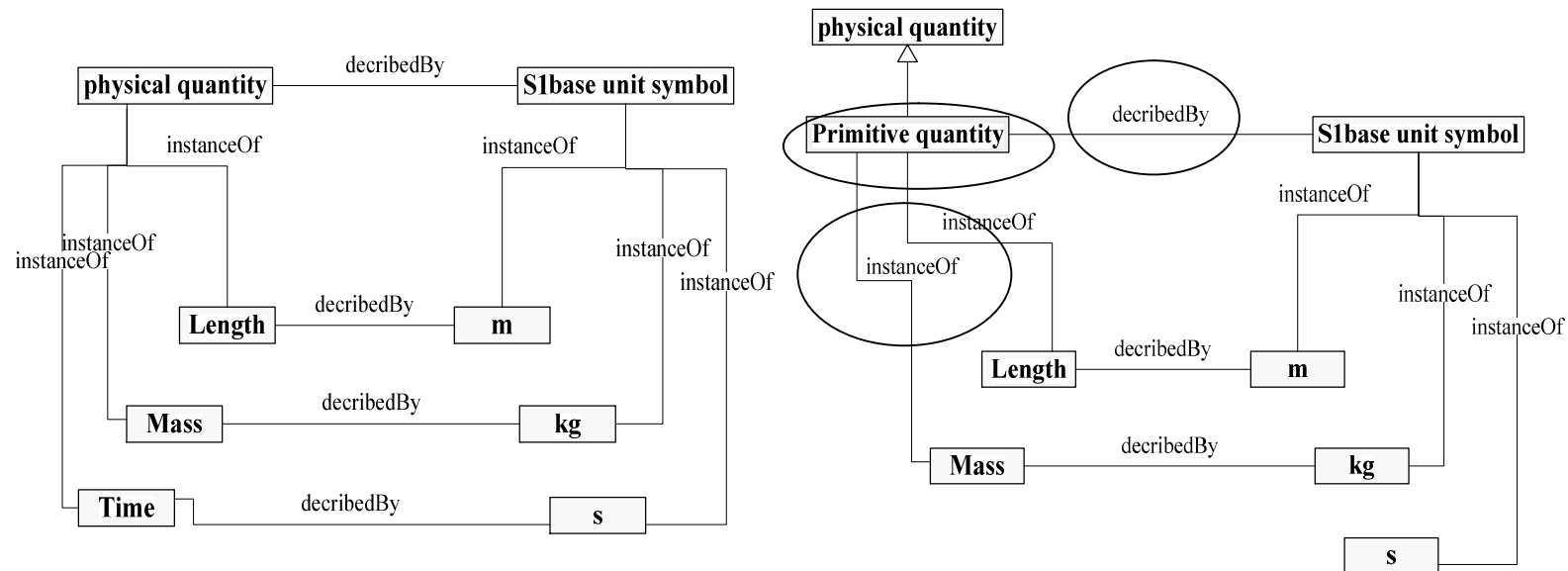

- User requested consistency
- {Length, Mass, Time}

- User requested consistency
- {Length, Mass, describedBy}

# $X \rightarrow X'$ (11/11)

## Evolution Strategy

---

### ✍ Input

- ✍ Change Closure
- ✍ Consistency Closure

### ✍ Output

- ✍ Additional Changes

✍ In some cases, several evolution strategies can satisfy user's requirement.

# Change Propagation (1/4)

---

Change to RO

$X \rightarrow X'$



Change to dependent RO

$Y \rightarrow Y'$

Change to dependent LO

$Z \rightarrow Z', W \rightarrow W'$

Change to LO

# Change propagation

## Z ~~Z'~~ (2/4)

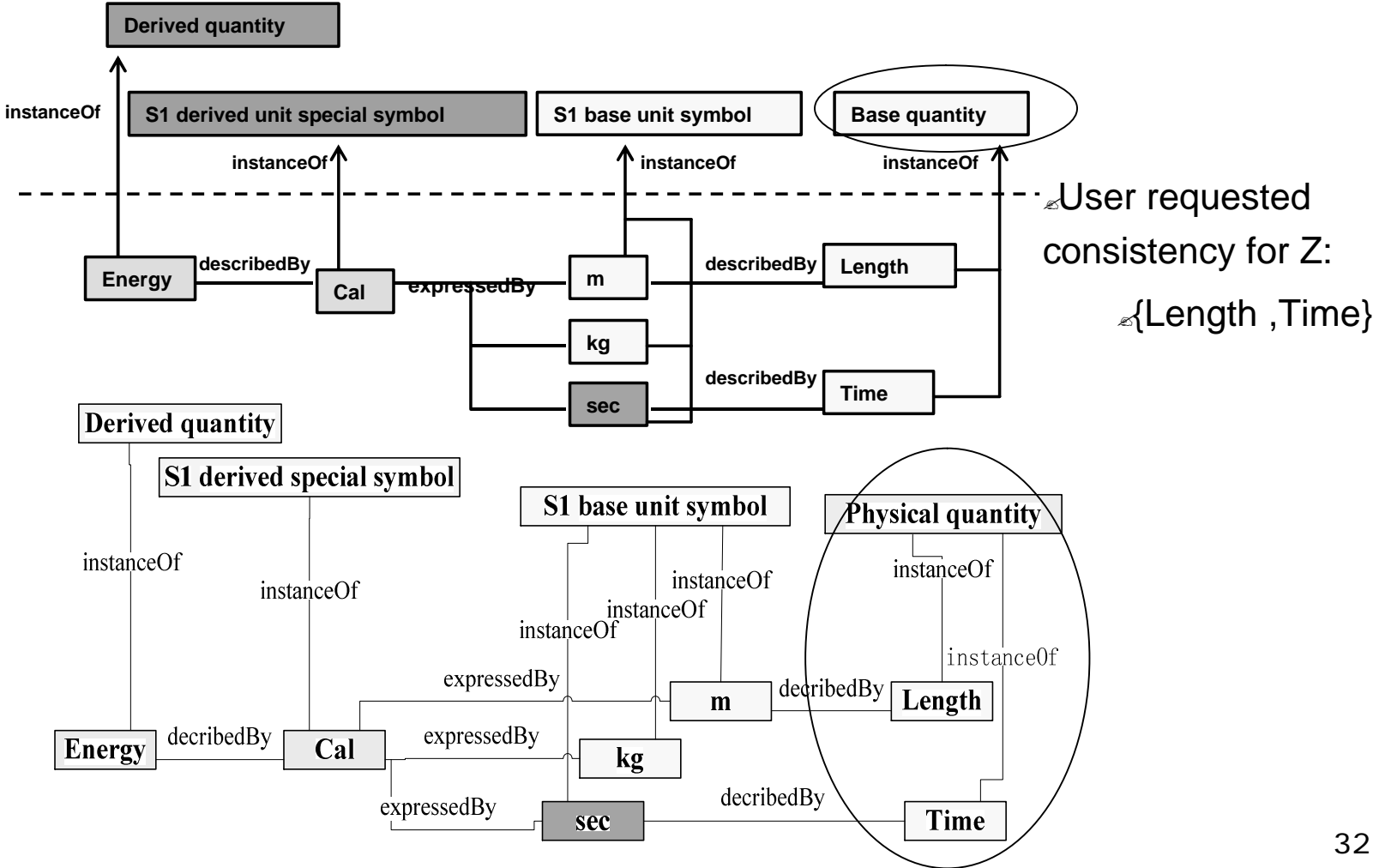

# Change propagation Strategy

## Z ~~Z'~~ (3/4)

---

### ✍ Input:

- ✍ Evolution Information about X
  - ✍ Change Closure
    - ✍ Delete concept (Base Quantity)
    - ✍ add property domain (physical quantity, describedBy ,S1 based physical quantity,
    - ✍ add instanceOf (Physical Quantity, Length),
    - ✍ add instanceOf (Physical quantity, Time)}
    - ✍ ...
  - ✍ Consistency Closure
  - ✍ Evolution Strategy
- ✍ User requested consistency for Z'
  - ✍ {Length ,Time}

### ✍ Output:

- ✍ delete Base Quantity
- ✍ add instanceOf (Physical Quantity, Length),
- ✍ add instanceOf( Physical quantity, Time)}
- ✍ ...

# Change Propagation (4/4)

---

## ✍ Input

- ✍ Calculation based on all the changes applied on X
  - ✍ Change closure
  - ✍ Consistency closure
  - ✍ Additional Changes based on Evolution Strategy
- ✍ Consistency Constraint for Z'

## ✍ Output

- ✍ Changes

# Ontology Evolution Management Metamodel

---

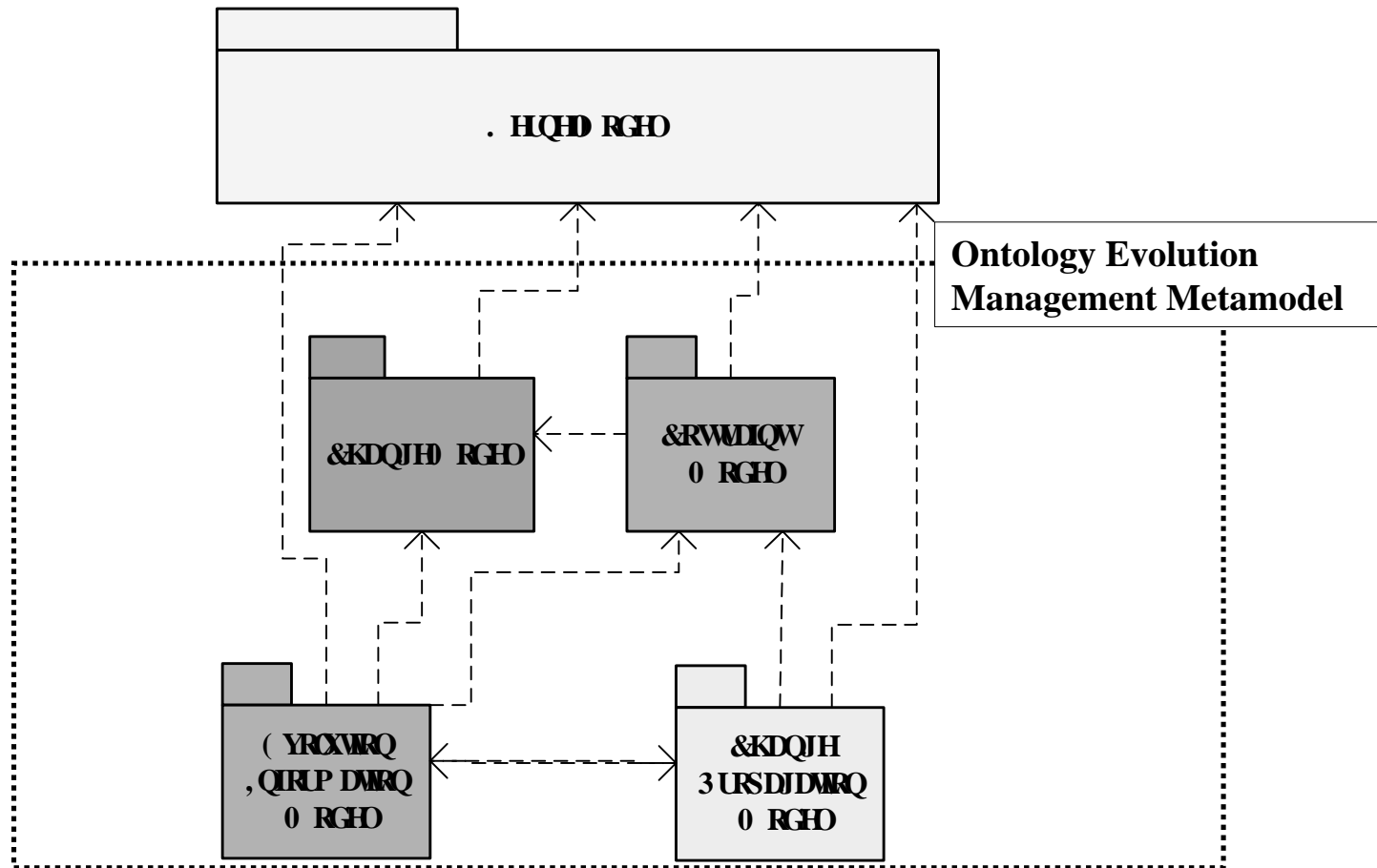

# Change Model

---

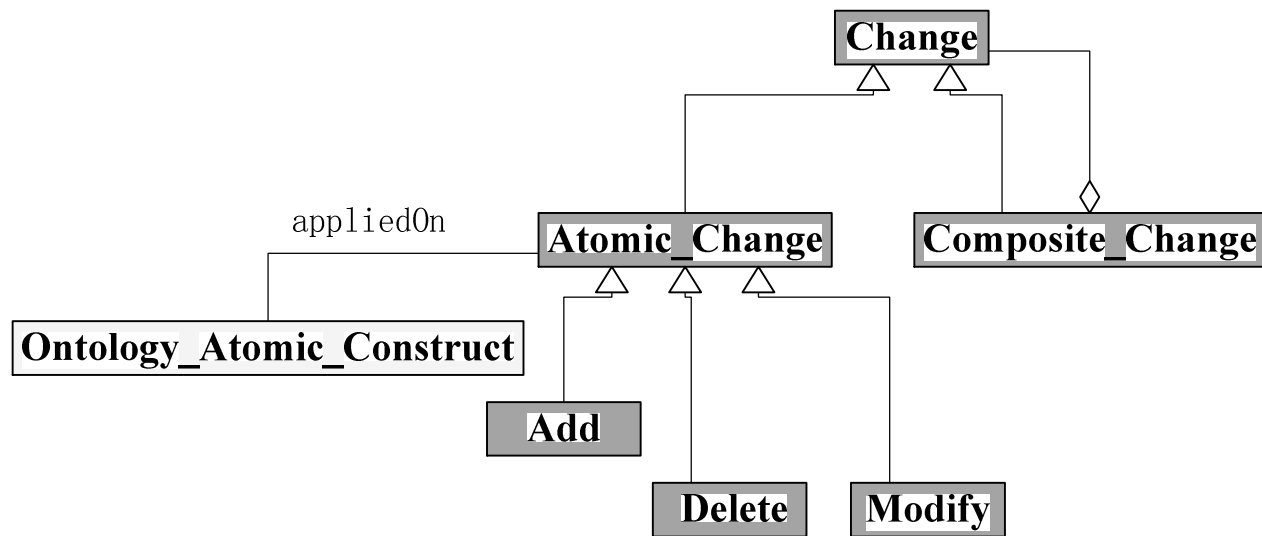

*From Kernel Model*



*From Change Model*



# Change Propagation Model

---

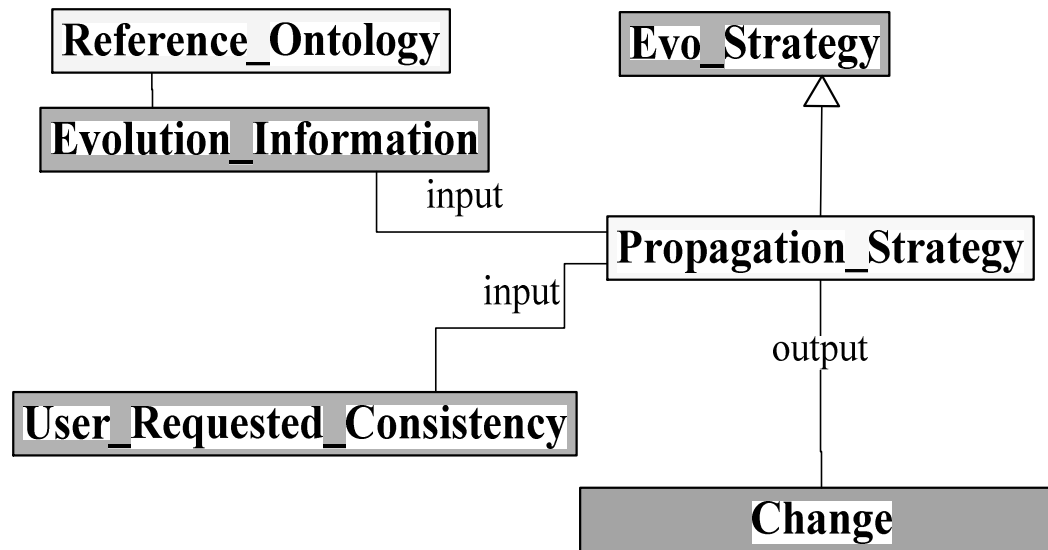

*From Kernel Model*



*From Change Model*



*From Constraint Model*



*From Evolution Information Model*



*From Propagation Model*

# Evolution Information Model

---

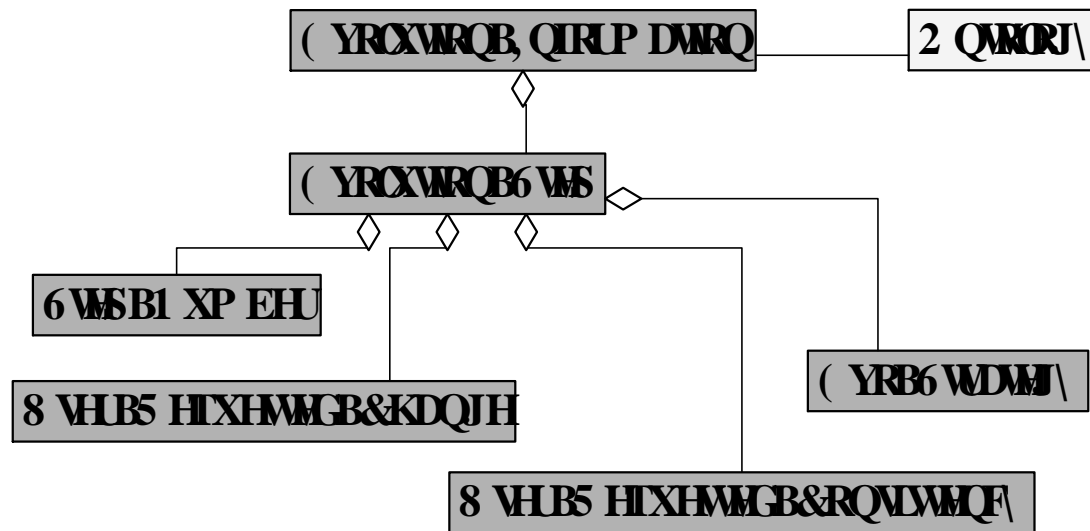

*From Kernel Model*



*From Constraint Model*



*From Evolution Information Model*

# Summary

---

- ✍ **How to registrate ontologies?**
  - ✍ Kernel Model
- ✍ **What kind of change can be identified and described by MFI-3?**
  - ✍ Change Model
    - ✍ Atomic and composite Change
- ✍ **How to realign the dependent ontologies during the evolution process?**
  - ✍ Constrain Model
    - ✍ Constraint between changes
    - ✍ Change Closure
    - ✍ Evolution Strategies
    - ✍ Consistency Constraint
    - ✍ Consistency Closure
  - ✍ Change Propagation Model
    - ✍ Change propagation Strategy
- ✍ **How to keep the evolution information about ontologies**
  - ✍ Evolution Information Model

# Talk Outline

---

1. Background
2. Overall design of MFI-3
3. Ontology Evolution Management Metamodel
4. Future Work

- 
- ✍ Improve Ontology Evolution Management Metamodel
  - ✍ MFI-3 & MFI-4
  - ✍ MFI-3 & ISO/IEC 11176-6

---

Thank you !



**hekeqing@public.wh.hb.cn**

**heyangfan927@163.com**

